

# CBT Trolley

## Plain or Geared Trolleys – Versatile, Economical, and Reliable

The smooth rolling CM Hoist CBT is the economical choice for most applications. The trolley features steel wrap around side plates, dual tread wheels and lifetime lubricated shielded ball bearings. The CBT Model by CM Hoist is available in plain and geared models.

- **Capacities** - Rated loads from 1/4 to 5 Ton (Metric Rated). In plain and geared models.
- **Economical** - Excellent low cost choice for manual and powered hoists.
- **Rugged** - Designed to provide superior performance and long, efficient service.
- **Low Rolling Effort** - Geared models have standard 6-foot hand chain drop. Other hand chain drops available.
- **Universal Hanging Clevis** - Accepts most hook mounted hoists.
- **Adjustable** - Trolley easily adjusts to fit any beam flange within range of adjustment, up to an 8.7" flange width.
- **Wrap-Around Side Plates** - Lugs provide additional security to increase operator safety and act as bumpers to protect wheels.
- **Dual Tread Wheels** - Will fit either tapered or flat beam flange within range of adjustment. Wheels include permanently lubricated, shielded ball bearings for long life and low maintenance.
- **Lifetime Warranty**



CBTP  
(Plain Trolley)  
1/4 To 5 Ton



CBTG  
(Geared Trolley)  
1 To 5 Ton

### SPECIFICATIONS - Model CBT

Capacity * (Ton)	Plain Product Code**	Geared Product Code**	Standard Beam Height (In.)	I-Beam Width (In.)	Minimum Radius Curve (In)	Wheel Tread Diameter (In)	Wt. (Lb.)
1/4	CBT(P)-0025		4-24	2.0-8.7	27	2.36	19
1/2	CBT(P)-0050		4-24	2.0-8.7	27	2.36	19
1	CBT(P)-0100	CBT(G)-0100	5-24	2.3-8.7	36	2.36	26
1 1/2	CBT(P)-0150	CBT(G)-0150	6-24	2.3-8.7	45	3.15	46
2	CBT(P)-0200	CBT(G)-0200	6-24	2.3-8.7	45	3.15	46
3	CBT(P)-0300	CBT(G)-0300	8-24	3.0-8.7	55	4.41	86
5	CBT(P)-0500	CBT(G)-0500	10-24	3.5-8.7	70	4.92	130

\* Metric Rated

\*\*When ordering specify "P" for plain trolley or "G" for geared trolley

## CBT Trolley - Specifications

Dimensional Drawing - 602

Model CBTP/CBTG 1/4-5 Metric Ton

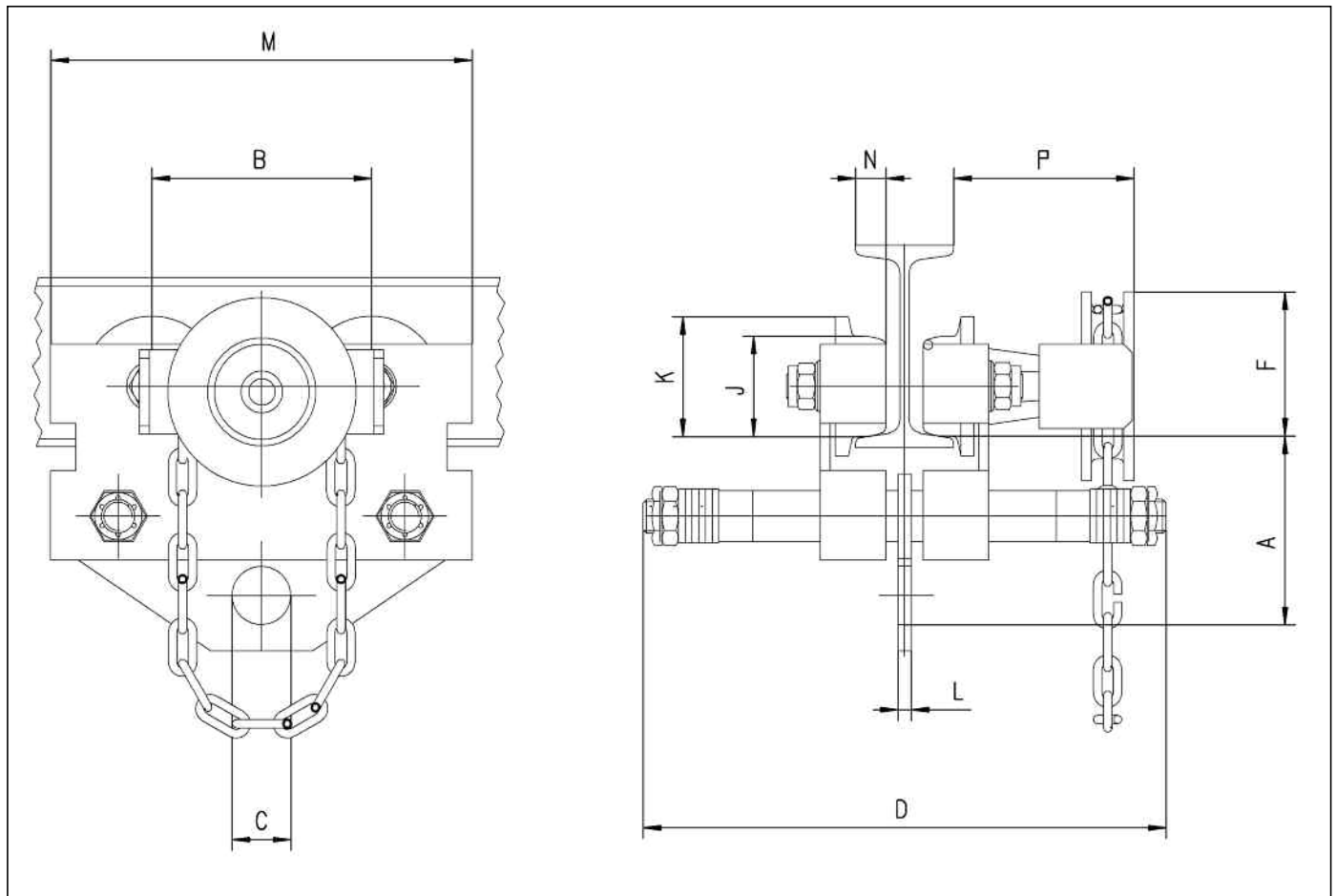

Clearance Dimensions (In.)

Model CBT

Capacity (Ton)	A	B	C	D	CBTG F	J	K	CBTG K	L	M	N	CBTG P
1/4	3.94	3.54	1.18	11.81	-	2.36	2.83	-	.31	7.56	.71	-
1/2	3.94	3.54	1.18	11.81	-	2.36	2.83	-	.31	7.56	.71	-
1	4.33	5.12	1.38	12.20	3.60	2.36	2.83	3.03	.31	9.84	.71	4.33
1 1/2	5.12	5.91	1.89	12.60	3.56	3.15	3.78	3.86	.47	11.81	.79	4.33
2	5.12	5.91	1.89	12.60	3.56	3.15	3.78	3.86	.47	11.81	.79	4.33
3	6.18	7.09	2.36	13.39	4.23	4.41	5.20	5.24	.55	14.57	1.14	4.33
5	7.09	8.23	2.76	13.78	5.89	4.92	5.63	5.87	.79	17.32	1.26	4.33